

Det. Top Of Pole  
SCALE 1 : 25

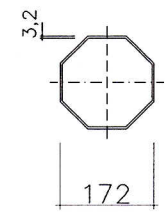

Det. Bottom Of Pole  
SCALE 1 : 25

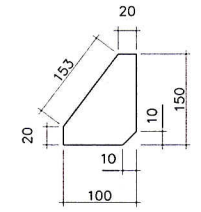

Rip Plate T = 6mm  
SCALE 1 : 25

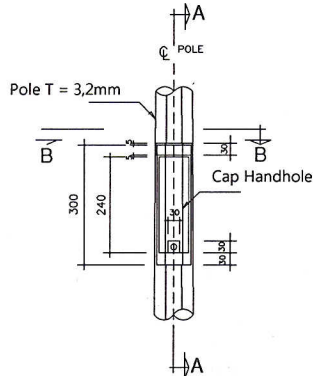

Det 2. Handhole  
SCALE 1 : 25

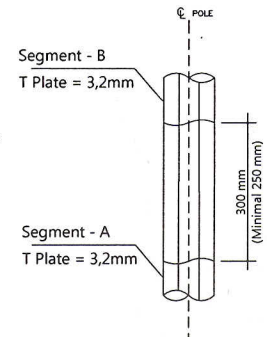

Det 3. Slip Joint  
SCALE 1 : 25

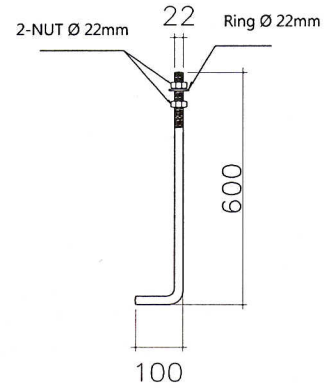

Det. Anchor Bolt  
SCALE 1 : 25

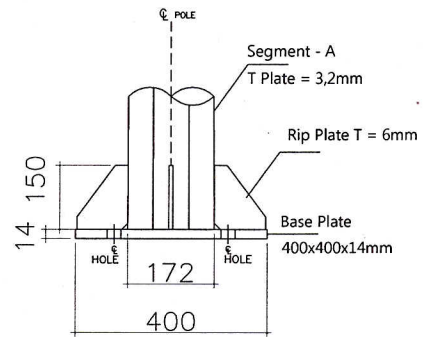

DET. 1 Base Plate  
SCALE 1 : 25

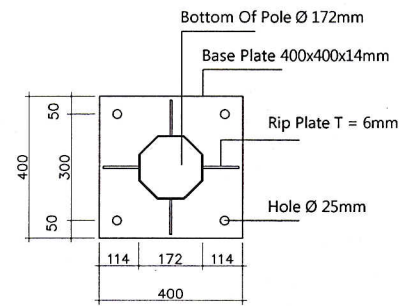

DET. 1 Base Plate  
SCALE 1 : 25

TIANG PJU H-12M DOUBLE PARABOLE  
SCALE 1 : 25

OCTAGONAL

KETERANGAN

STANDART MUTU :

- ISO 9001 : 2008
- Plate Baja : ST 41 / SS 400
- Welding : Las Listrik
- Finishing Hot Dip Galvanize
- Segment System Slip Joint
- Segment A = 4000mm
- Segment B = 6000mm
- Segment C = 2600mm
- Bottom Of Pole Ø 172mm
- Base Plate 400x400x14mm

PRODUCTION :



PT. HELORI GRAHASARANA

JOB TITLE :

TECHNICAL SPECIFICATION

CLIENT :

PROJECT :

DRAWING TITLE :

TIANG PJU OCTAGONAL  
H-12M DOUBLE PARABOLE

DATE	CLIENT APPROVAL	APPROVAL
	Dwi. Y	Efi
CAD	DESIGN	CHECK
Auto CAD 2009		

DRAWING NO : RL-DP-H12	SHEET NO : SHEET 1 Of 1
---------------------------	----------------------------